



CR80
3 Up Key Tag

Prepress & Media

We are able to handle both conventional and digital materials offering the maximum flexibility.

Conventional

1 up right reading negative film emulsion down with a 150 line screen. Do not include keylines. If 4 colour process please include a colour key. Please review layout information.

Digital

We can accept files in PC or MAC format.

MAC Quark 4.1

Adobe Illustrator 8 or 9 Adobe PageMaker 7.5

Adobe Photoshop 7 In Design 2.1

EPS Corel Draw 9

Ensure that all text is converted to curves or you must include all fonts. We can accept CDs, 3.5 diskettes and zip files under 4 megs via e-mail.

Check your cd's to include:

Fonts + Photo's + Images + Text

Layout & Design

Image Area

Design layout to size 21 X 54mm (1.125 X 2.125 in) 3 up. Do not include the keylines in the design. Non bleed art should be 3mm (.125 in) inside the finished edge of the card.

Bleeds

All bleeds should extend 3mm (.125in) beyond the finished size. In a colour bleed for the 3 up design bleed the full size of the card once as opposed to 3 times in the tag design

Reversed Type

Reverse type that knocks out all printed colours should be at least 8pt type in San Serif typeface. Closed or delicate typefaces or smaller point sizes may fill in especially if the colour is dark and requires two hits.

Layout & Design contd.

Bleeds

All bleeds should extend 3mm (.125in) beyond the finished size. Be aware that the bleed must be a colour and not a photo due to 3 up print style. A photo image may not be consistent when run 3 up.

Reversed Type

Reverse type that knocks out all printed colours should be at least 8pt type in San Serif typeface. Closed or delicate typefaces or smaller point sizes may fill in especially if the colour is dark and requires two hits.

Personalization Areas

Thermal print and inkjet areas must be at least 3mm (.125 in) from any edge or the magnetic stripe. If a bar code is to be applied a knockout area of a 45 X 13mm (1.8 X .500 in) minimum will be required. The bar code layout must have space for quite zones in the upper left and right of the area. Please specify the bar code type to be used most must be a minimum of 10.7 mm .420 in in height, approximately 36pt.

Front

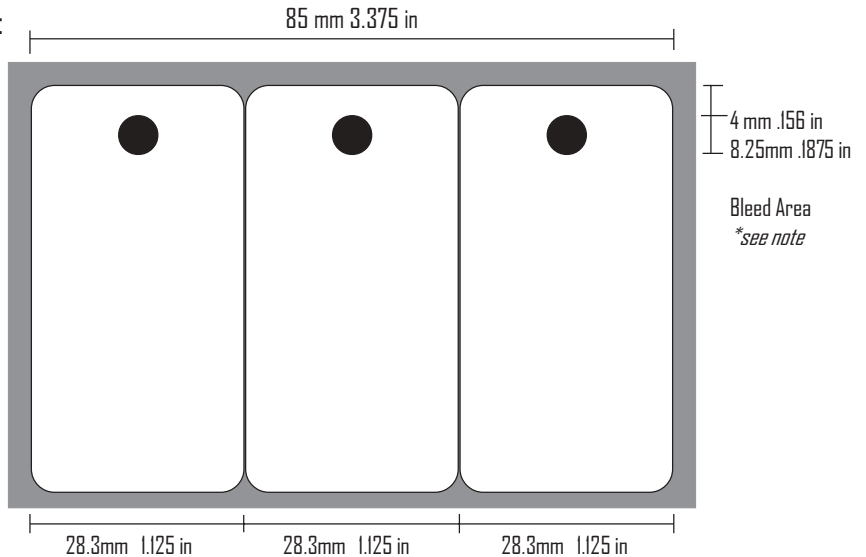

Back

